

AS-Distribution GmbH
Hillenbrandstraße 10
73079 Sülben / Germany

Phone +49 7162 9474450
E-Mail info@as-distribution.de
www.acoustic-signature.com

Managing Director
Gunther Frohnhöfer
Jacqueline Frohnhöfer

MERLIN



The MERLIN turntable weighs in at 16 kg and marks our new entry to our series of mass turntable. With the MERLIN design, we bring together one of the most sophisticated external drive and power supply systems, with a massive turntable design at a very reasonable price. It's all combined with the award-winning performance, elegance, convenience and comfort that have made our mass turntable series so successful all over the world but at a lower price point.

At the new MERLIN we combine a massive aluminum plinth of 40 mm with a 34 mm massive 6,4 kg aluminum platter. All parts in high gloss polished surface. Additional coating on the back side with a high damping material further improves the resolution and fine dynamics. This is a perfect fit for the Tidorfolon-bearing spinning the platter. Our analog motor electronic provides perfect speed stability and easy operation. All parts together result in the sound of the MERLIN so outstanding for his price class.

We at ACOUSTIC SIGNATURE believe that a motor system for a turntable should have enough energy to speed up the platter but not influence him during rotation. We reach that aim by using a European made synchronous motor with our own motor control. This drive system is absolute stable in his rotation speed easy to use and reliable.

The bearing is the heart of every turntable. At the base of the bearing, we use our specially developed „high-tech“ material Tidorfolon. The Tidorfolon-bearing is life time maintenance free and covered with a 10 year warranty.

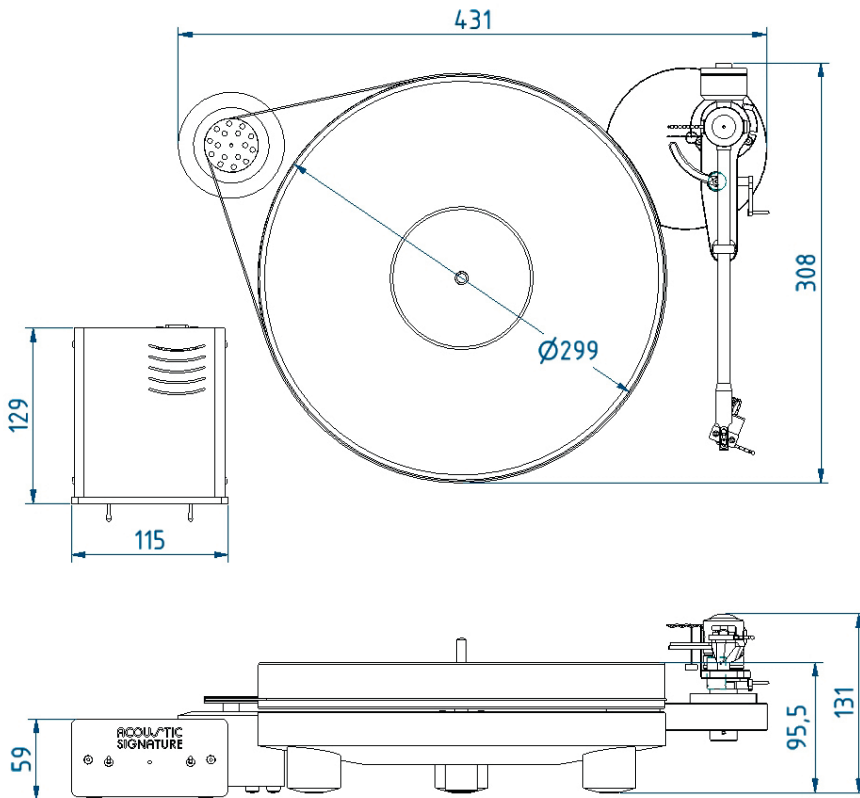

TECHNICAL DATA

	MERLIN
Dimensions (width x height x depth)	430 mm x 135 mm x 340 mm
Weight	ca. 15 kg depending on extras
Drive System	1 Synchronius motor, electroically driven, internal motor electronic, ALPHA-S motorelectronic
Speed range	33 1/3 RPM, 45 RPM with motor electronic
Power supply	96 V to 230 V AC
Bearing	High precision Tidorfolon-bearing
Chassis	Vibration damped Chassis, 3 height adjustable feet, soft alloy for low resonance
Platter	High precision platter made of aluminum, 3,4 cm height, weight: 6,4 kg